

OLD DWG.NO.:083	DATE :AUG.2005	REV : 00	N.A	SHEET : 1 OF 2	APPD. BY : ✕
OLD DWG.NO.:DP-5.8/11-460	DATE :APR. 2011	REV : 00	ADDITIONAL INFORMATION IS ADDED		
NEW DWG.NO.:DP-5.8/MT-350	DATE :NOV. 2017	REV : 01	ADDITIONAL INFORMATION IS ADDED		

**INTRODUCTION :-**

ON LINE MONITOR IS USED IN CO2 GAS BASED FIRE EXTINGUISHING SYSTEM TO PROVIDE REFILL ALERT INDICATION INCASE OF LOSS OF AGENT AS PER DESIGN STANDARDS. MOVEMENT OF INDICATOR IN DOWNWARD POSITION INDICATES ALERT STATUS. EX.PROOF LIMIT SWITCH CAN BE ADDITIONALLY USED TO PROVIDE FURTHER SIGNAL AT CONTROL PANEL.

**NOTE:** \* THIS DEVICE IS NOT WEIGHING UNIT. THIS WILL ONLY PROVIDE ALERT TO CHECK THE CYLINDER AND DO REFILL AS PER REQUIREMENT.

THIS UNIT ALSO CAN BE REFERRED AS "CONTINUOUS GAS WEIGHT MONITOR MECHANICAL COUNTER WEIGHT TYPE WITH EXPLOSION PROOF LIMIT SWITCH".

\* THIS DATASHEET CAN BE ALSO REFERRED AS DP-5.8/CP-350.

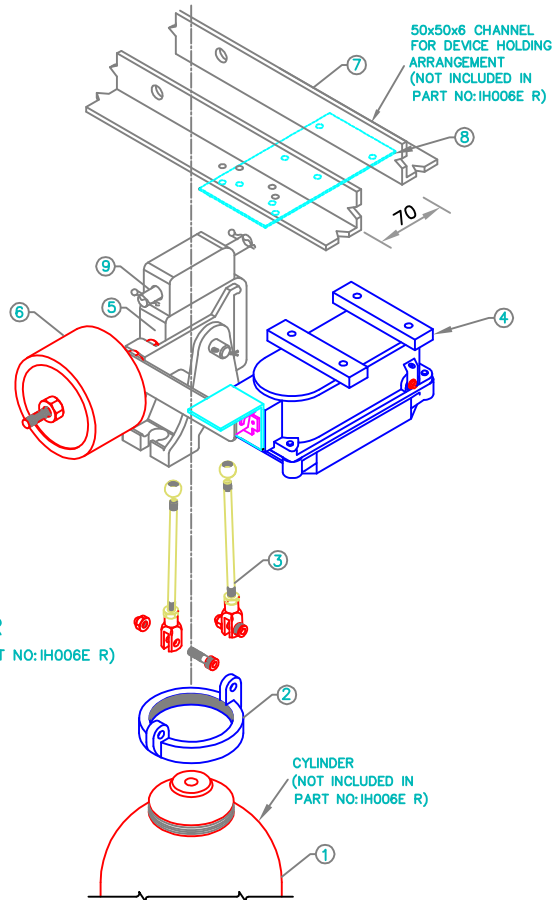
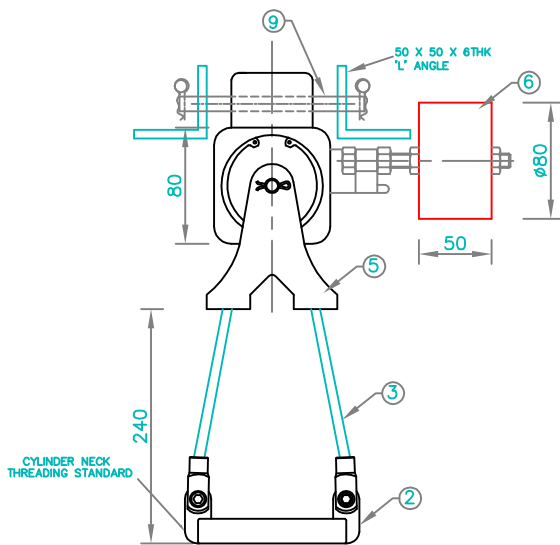

**NOTE:-**

- 1 - 6.8 TO 68 LITRES WATER CAPACITY CO2 CYLINDER FILLED WITH 4.5 TO 45KG CO2 GAS (NOT INCLUDED IN PART NO: IH006E R)
- 2 - CYLINDER COLLAR. (ALUMINIUM)
- 3 - HANGER ROD ASSEMBLY (NON FERROUS).
- 4 - EX.PROOF LIMIT SWITCH
- 5 - WEIGHT MONITOR MAIN ACTUATION PART
- 6 - INDICATOR ASSEMBLY
- 7 - RAIL ASSEMBLY
- 8 - LIMIT SWITCH MOUNTING PLATE
- 9 - M10 ROD

- 1. SUITABLE MODEL CAN BE SELECTED AS PER ANNEXURE-A REFER PAGE 2
- 2. ALL DIMENSIONS ARE IN "mm" UNLESS OTHERWISE SPECIFIED.
- 3. TOLERANCE ON DIMENSION ± 3 mm, UNLESS OTHERWISE SPECIFIED.
- 4. INDICATOR SIZE VARY DEPENDS ON CO2 GAS WEIGHT PLUS CYLINDER TARE WEIGHT PLUS VALVE WEIGHT.
- 5. NOT TO SCALE.

**TECHNICAL SPECIFICATION**

01. MAKE	AGNI CONTROLS - CHENNAI	04. EX.PROOF LIMIT SWITCH	
02. OPERATION	MOVEMENT OF INDICATOR IN DOWNWARD POSITION SHOWS REFILL ALERT	a) MAKE	FLAME PROOF EQUIPMENT PVT LTD.,
03. MATERIAL OF CONSTRUCTION		b) MODEL NO	FLP-RH-03 IIC Ex 'd'
	a) ON LINE MONITOR	c) GAS GROUP	IIA, IIB & IIC AS PER IS:2148 04
	b) COLLAR	d) MATERIAL	ALUMINIUM ALLOY LM6
	c) HANGER ROD	e) APPROVAL	CIMFR
		f) RATING	UP TO 20A, 500 V AC

**IMPORTANT:**

AGNI CONTROLS RESERVES THE RIGHT TO CHANGE OR MODIFY WITHOUT PREVIOUS NOTICE ANY DATA OR SPECIFICATION DUE TO CHANGES OR MODIFICATION IN ORDER TO IMPROVE THE PRODUCTS / SYSTEM PRESENTED.

DATA SHEET

**ON LINE MONITOR MECHANICAL INDICATOR TYPE  
WITH EXPLOSION PROOF LIMIT SWITCH**

PART NO : IH006E R

OLD DWG.NO.:083	DATE :AUG.2005	REV : 00	N.A	SHEET : 2 OF 2	APPD. BY : ✕
OLD DWG.NO.:DP-5.8/11-460	DATE :APR. 2011	REV : 00	ADDITIONAL INFORMATION IS ADDED		
NEW DWG.NO.:DP-5.8/MT-350	DATE :NOV. 2017	REV : 01	ADDITIONAL INFORMATION IS ADDED		

**ANNEXURE : ADDITIONAL INFORMATION TO SELECT MODEL NO.**

SL.NO	PART NO	DESCRIPTION
01	IH006R	ON LINE MONITOR - MECHANICAL INDICATOR TYPE
01-1	IH006R P1-PIN	MAIN WEIGHING UNIT ASSEMBLY-PIN TYPE
01-2	IH006R P1-NUT	MAIN WEIGHING UNIT ASSEMBLY-NUT TYPE
01-3	IH006R P2/40-50	INDICATOR ASSEMBLY SUITABLE FOR TYPE 1
01-4	IH006R P2/30-40	INDICATOR ASSEMBLY SUITABLE FOR TYPE 2
01-5	IH006R P2/20-30	INDICATOR ASSEMBLY SUITABLE FOR TYPE 3
01-6	IH006R P2/10-20	INDICATOR ASSEMBLY SUITABLE FOR TYPE 4
01-7	IH006R P2/02-10	INDICATOR ASSEMBLY SUITABLE FOR TYPE 5
01-8	IH006R P3	COLLAR ASSEMBLY-Ø80mm
01-9	IH006R P3 WOR	COLLAR ASSEMBLY-Ø80mm WITHOUT HANGING ROD
01-10	IH006R P3/SP	SPLIT COLLAR ASSEMBLY-Ø80mm
01-11	IH006R P3/SP WOR	SPLIT COLLAR ASSEMBLY-Ø80mm WITHOUT HANGING ROD
01-12	IH006R P4	COLLAR ASSEMBLY-Ø95mm
01-13	IH006R P4 WOR	COLLAR ASSEMBLY-Ø95mm WITHOUT HANGING ROD
01-14	IH006R P4/SP	SPLIT COLLAR ASSEMBLY-Ø95mm
01-15	IH006R P4/SP WOR	SPLIT COLLAR ASSEMBLY-Ø95mm WITHOUT HANGING ROD
01-16	IH006E R P5	EXPLOSION PROOF LIMIT SWITCH ASSEMBLY
01-17	IH006R P6 WOR	M.S FLANGE TYPE COLLAR-Ø95mm WITHOUT HANGER ROD
01-18	IH006R P6/SP WOR	M.S SPLIT FLANGE TYPE COLLAR-Ø95mm WITHOUT HANGER ROD
01-19	IH006R P6/1	M.S FLANGE TYPE LARGER DIA COLLAR - Ø95mm
01-20	IH006R P7 WOR	M.S FLANGE TYPE COLLAR - Ø80mm WITHOUT HANGING ROD
01-21	IH006R P7/SP WOR	M.S SPLIT FLANGE TYPE COLLAR - Ø80mm WITHOUT HANGING ROD
01-22	IH006R P7/1	M.S FLANGE TYPE LARGER DIA COLLAR - Ø80mm
01-23	IH006R P3 HROD*	1 PAIR HANGER ROD (* -190,275,325)
01-23-01	IH006R P3 HROD-190	1 PAIR HANGER ROD -190
01-23-02	IH006R P3 HROD-275	1 PAIR HANGER ROD 275
01-23-03	IH006R P3 HROD-325	1 PAIR HANGER ROD 325
01-24	IH006R P3-FG HROD*	1 PAIR HANGER ROD SUITABLE FOR FLANGE TYPE COLLAR (*- 190,275,325)
01-24-01	IH006R P3 -FG HROD-190	1 PAIR HANGER ROD SUITABLE FOR FLANGE TYPE COLLAR - 190
01-24-02	IH006R P3 -FG HROD-275	1 PAIR HANGER ROD SUITABLE FOR FLANGE TYPE COLLAR - 275
01-24-03	IH006R P3-FG HROD-325	1 PAIR HANGER ROD SUITABLE FOR FLANGE TYPE COLLAR - 325

**EXAMPLE:**

MODEL NO: **IH006E R** **01-1** **01-3** **01-8**

**IMPORTANT:**

AGNI CONTROLS RESERVES THE RIGHT TO CHANGE OR MODIFY WITHOUT PREVIOUS NOTICE ANY DATA OR SPECIFICATION DUE TO CHANGES OR MODIFICATION IN ORDER TO IMPROVE THE PRODUCTS / SYSTEM PRESENTED.



**AGNI CONTROLS  
CHENNAI**

NO.1, 6TH STREET, Dr.SUBBARAYAN NAGAR,  
KODAMBAKKAM, CHENNAI-600 024, INDIA.

PHONE : +91 44 2481 2420, FAX : +91 44 2481 2475,

E-MAIL : engineering@agnicontrols.com WEBSITE : www.balafire.com

ISO 9001 - 2008  
CERTIFIED BY  
BUREAU VERITAS