

**DATA SHEET**

## CYLINDER FIXING BRACKET

PART NO: IH353

DP-5.8/08-122

DATE : OCT-2009

REVISION : 00

SCALE : N.T.S

SHEET : 1 OF 1

APPD. BY: D.B.

**INTRODUCTION :-**

BRACKET IS SUITABLE TO CLAMP ONE CYLINDER ON WALL OR FIXED SUPPORT

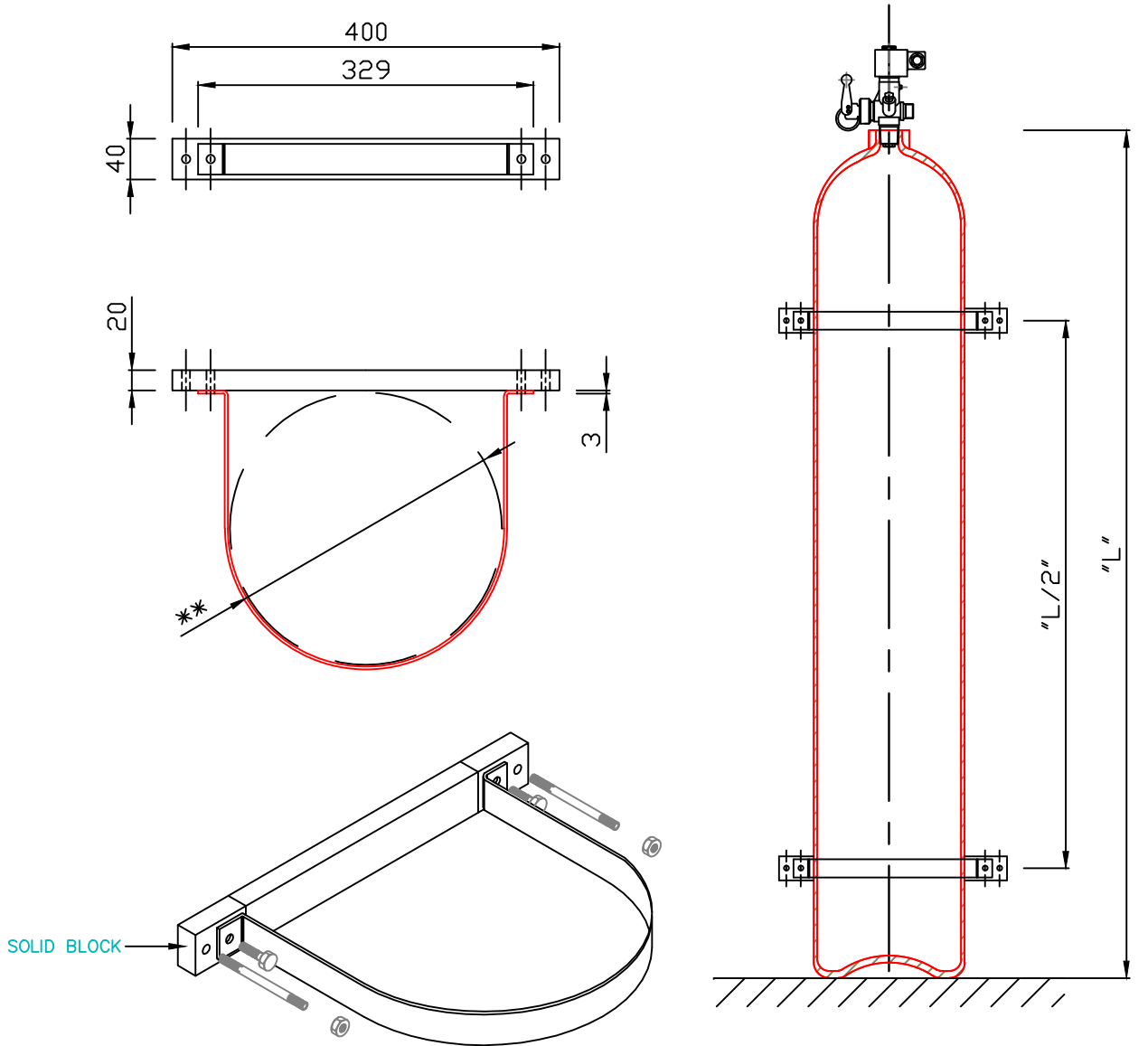

\*\* 271 - SUITABLE FOR Ø267 CYLINDERS  
 \*\* 236 - SUITABLE FOR Ø232 CYLINDERS

ALL DIMENSIONS ARE IN "mm" UNLESS OTHERWISE SPECIFIED.

### TECHNICAL SPECIFICATION

01.	MANUFACTURER	AGNI CONTROLS, CHENNAI.	
02.	BASE CLAMP	40x20 MS TUBULAR	
03.	CYLINDER BRACKET	30x3mm MS FLAT	
04.	M10x25 BOLT WITH WASHER	SS-304	
05.	M10x100 ANCHOR FASTENERS	MS (ZINC COATED)	

**IMPORTANT:**

AGNI CONTROLS RESERVES THE RIGHT TO CHANGE OR MODIFY WITHOUT PREVIOUS NOTICE ANY DATA OR SPECIFICATION DUE TO CHANGES OR MODIFICATION IN ORDER TO IMPROVE THE PRODUCTS / SYSTEM PRESENTED.

**AGNI CONTROLS  
CHENNAI**

NO.1, 6TH STREET, Dr.SUBBARAYAN NAGAR,  
KODAMBAKKAM, CHENNAI-600 024, INDIA.

PHONE : +91 44 2481 2420, FAX : +91 44 2481 2475,  
E-MAIL : [engineering@agnicontrols.com](mailto:engineering@agnicontrols.com) WEBSITE : [www.balafire.com](http://www.balafire.com)

ISO 9001 - 2008  
CERTIFIED BY  
BUREAU VERITAS