

**DATA SHEET**

## ADDRESSABLE MANUAL CALL POINT FOR INDOOR & OUTDOOR APPLICATION

PART NO :  
IH039/1W-AD

DP-5.8/09-207

DATE : DEC-2009

REVISION : 00

SCALE : N.T.S

SHEET : 1 OF 1

APPD. BY :DB

INTRODUCTION :-

ADDRESSABLE MANUAL CALL POINT IS USED TO ACTIVATE FIRE ALARM WARNING. MCP IS TO BE USED WITH NOTIFIER MAKE CONTROL PANEL WHEN GLASS OF MCP IS BROKEN, PUSH SWITCH IS RELEASED TO CAUSE NO AND NC STATUS CHANGE.

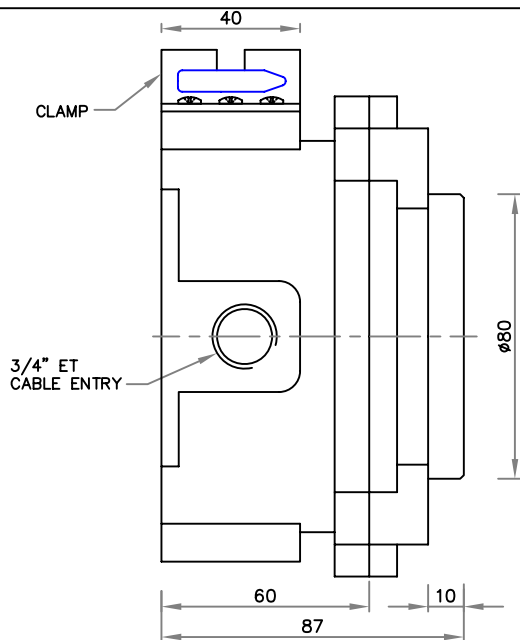

**SIDE VIEW**

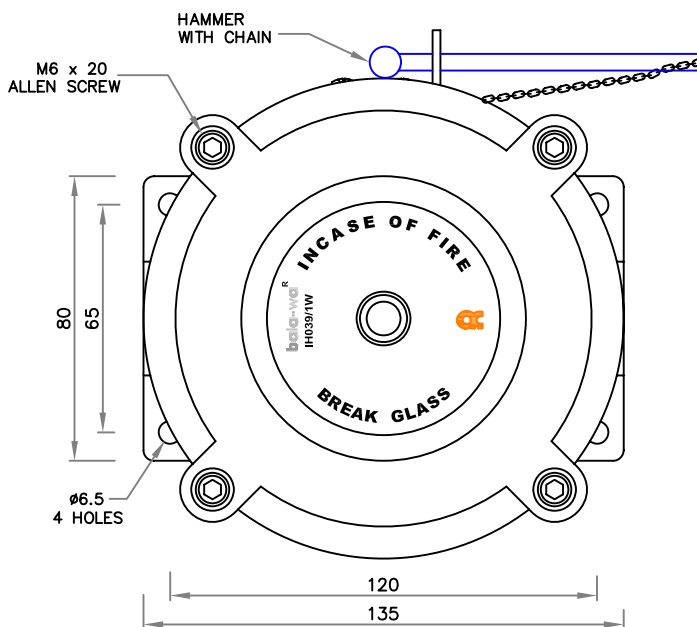

**ELEVATION**

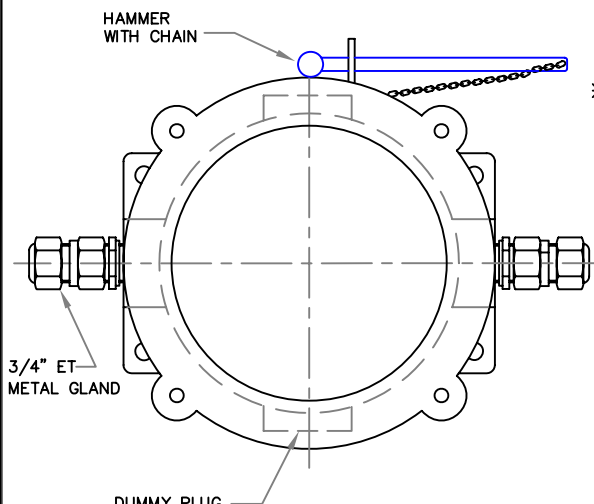

**FRONT VIEW**

- \* 1. SWITCH IS KEPT IN PRESSED CONDITION BY FRONT GLASS. IT IS OPEN AT THIS CONDITION.
- 2. IN CASE OF BREAKING GLASS, SWITCH WILL BE RELEASED, CONTACT WILL BE CLOSED, THUS ACTUATE ALARM THROUGH PANEL.
- 3. FMM 101 ADDRESSABLE MODULE IS PROVIDE WHICH CANBE CONNECTED ONLY WITH NOTIFIER MAKE FIRE ALARM PANEL.

**INTERNAL WIRING**

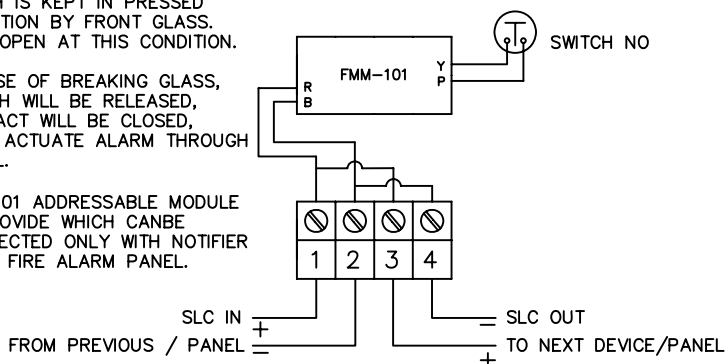

NOTE:

- 1. TOLERANCE ON DIMENSION  $\pm 3$  MM, UNLESS OTHERWISE SPECIFIED.
- 2. ALL DIMENSIONS ARE IN "mm" UNLESS OTHERWISE SPECIFIED.

**TECHNICAL SPECIFICATION**

01.	MANUFACTURER	AGNI CONTROLS - CHENNAI	06.	CONTACT ELEMENT	1 NO + 1 NC
02.	MODEL NO.	IH039	07.	FASTENERS	SS 304
03.	MATERIAL	CAST ALUMINIUM LM6	08.	PROTECTION CLASS	IP 66
04.	FINISH	POWDER COAT- RED TEXTURED	09.	CURRENT CONSUMPTION	UPTO 50MA
05.	CABLE ENTRY	3/4" ET - 3 Nos.			

IMPORTANT:

AGNI CONTROLS RESERVES THE RIGHT TO CHANGE OR MODIFY WITHOUT PREVIOUS NOTICE ANY DATA OR SPECIFICATION DUE TO CHANGES OR MODIFICATION IN ORDER TO IMPROVE THE PRODUCTS / SYSTEM PRESENTED.



**AGNI CONTROLS  
CHENNAI**

**ISO 9001 - 2008  
CERTIFIED BY  
BUREAU VERITAS**

NO.1, 6TH STREET, Dr.SUBBARAYAN NAGAR,  
KODAMBAKKAM, CHENNAI-600 024, INDIA.

PHONE : +91 44 2481 2420, FAX : +91 44 2481 2475,

E-MAIL : engineering@agnicontrols.com WEBSITE : www.balafire.com